

Samenstellingsdocument

Pouch



Inhoud

1. Schematische tekening	03
2. Technische tekening	04
3. Details	05
4. Binnenkant van de tas	07
5. Aandachtspunten	08
6. Prototype	10

Schematische tekening

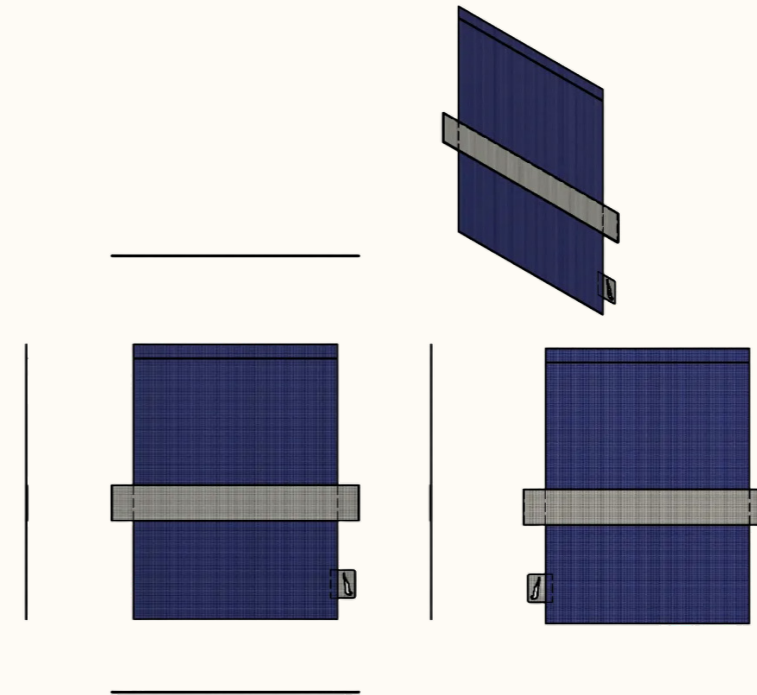

Technische tekening

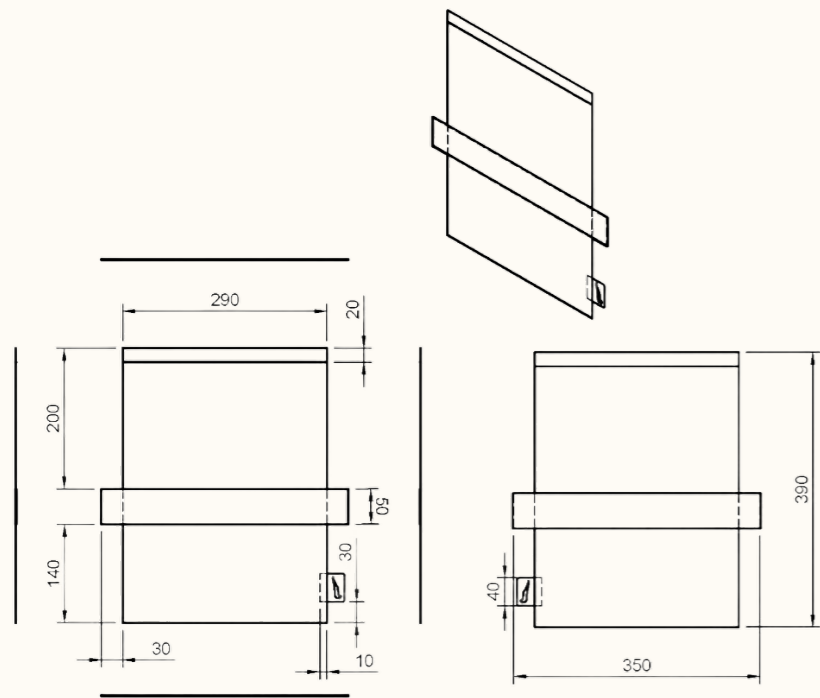

Details

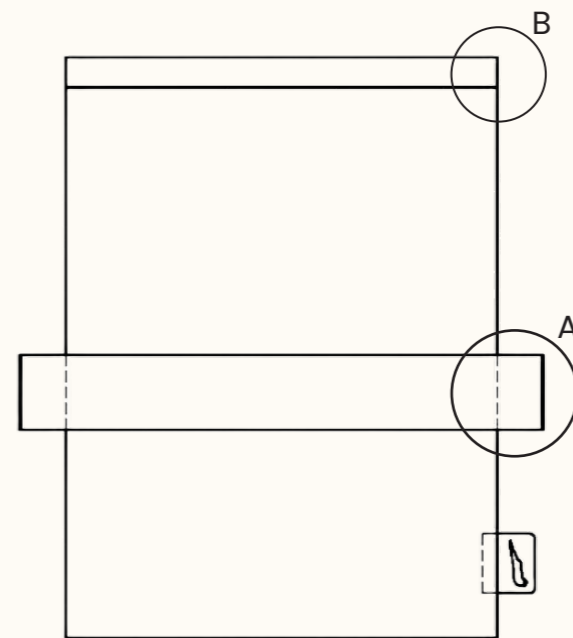

Detail A
Verbinding crossbody strap

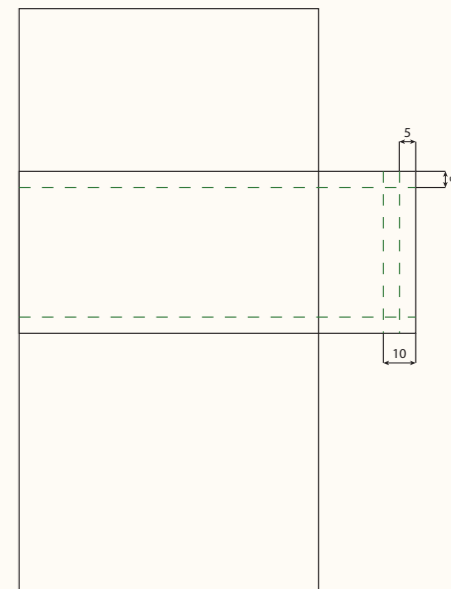

Detail B

Treksluiting touw knopen

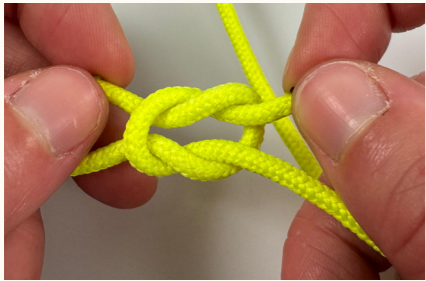

Binnenkant van de tas



Aandachtspunten

1. Het zeiltouw van 8mm moet door deze doorgang kunnen zonder teveel weerstand (afbeelding 1).
2. De uiteindes van het treksluiting touw zijn gebrand zodat deze niet gaat rafelen (afbeelding 2).
3. Let op dat de stiksels op de juiste afstanden zitten van de randen.
4. Let op dat het stiksel van de body tot het stiksel van de treksluiting loopt en deze goed is afgewerkt. Ivm behoudt tas (afbeelding 3).
5. Let erop dat het label juist geplaatst wordt (afbeelding 4).



Prototype

